

DOUBLE CONE BLENDER

Tapasya's Double Cone Blender is an efficient and versatile equipment for mixing of powder such as pharmaceutical excipients, various chemicals, food products homogeneously. With an effective volume for optimum homogeneity between 35-70% of gross volume, and a SLANT double cone design that eliminates dead spots, this Double cone blender is ideal across various industries including pharmaceutical, food, chemical, cosmetics, etc.



Features:

- Conical shape and elongated plane at both ends enables uniform mixing and easy discharge
- The cone is statically balanced which protects the gear box and motor from any excessive load
- Powder is loaded into the cone through a wide opening and discharged through a butterfly or a Slide valve
- Depending upon the characteristic of the product, paddle type baffles can be provided on the shaft for better mixing, uniform blending and de-agglomeration
- Contact parts are made of SS 304 or SS 316L
- Flame proof electricals can be provided
- 'Slant' design
- Variable speed option available 70%~
- Dust free bin charging system



Asymmetric Double Cone Design



Sanitary Butterfly Valve

Benefits For You:

- Homogenised blending of solid components
- Advanced design with custom made additional features for varying speed, safety (flame-proof) and varying capacities
- Minimal material handling
- Ideal for various applications in solid mixing



Double Pillar Mounted



Single Pillar Mounted

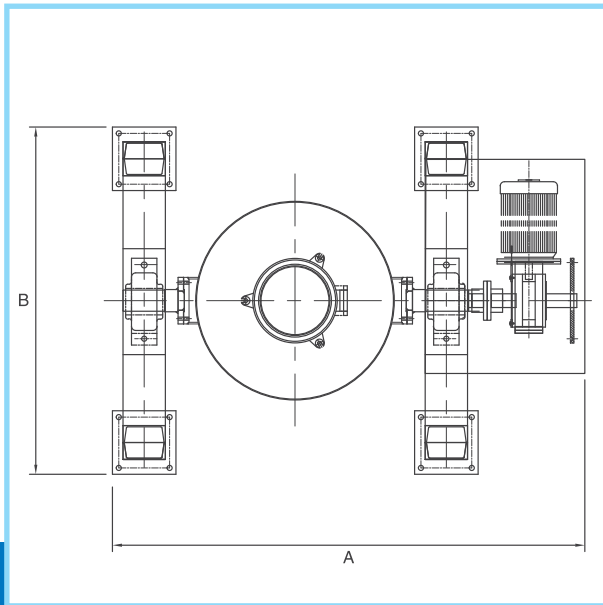

Plan view

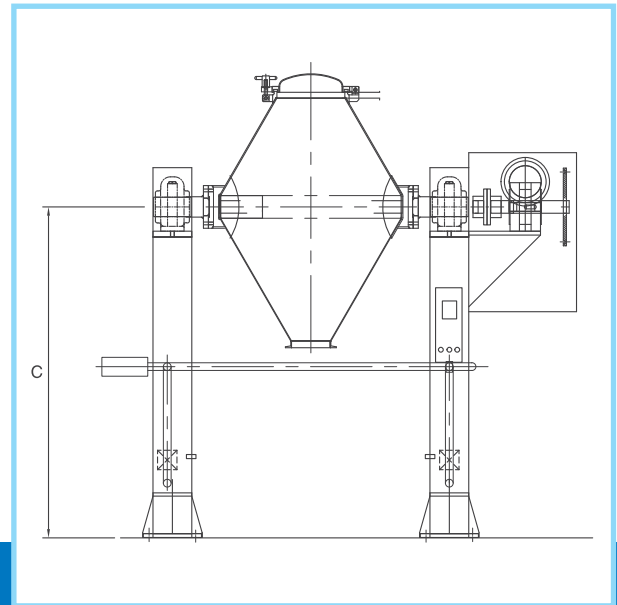

Elevation view

Technical Specifications:

MODEL	GROSS CAPACITY (in Liters)	WORKING CAPACITY (in Liters)	OVERALL DIMENSIONS (in mm)			MOTOR HP	APPROX. WEIGHT (in kg)
			L	B	H		
TAP-DC-75	75	53	1200	950	1650	2	700
TAP-DC-150	150	105	2000	1200	2250	3	700
TAP-DC-300	300	210	2100	1400	2350	5	800
TAP-DC-500	500	350	2350	1500	2500	7.5	1200
TAP-DC-1000	1000	700	2700	1800	3000	10	1800
TAP-DC-2000	2000	1400	3250	2400	3550	15	2500
TAP-DC-4000	4000	2800	4200	3000	4500	20	3000

Customised sizes available on request
Laboratory model design available

Double Cone Blender used in Industries:

- Pharmaceutical
- Nutraceutical
- Food
- Cosmetics